

Clean Air Solution





BIOSAFETY CABINET INTRODUCTION:

The Class II biological safety cabinet is a negative pressure safety device which is mainly used for handling pathogenic biological samples or for applications that require a sterile work zone. It adopts advanced air purification technology and negative pressure box design, and it realizes the protection of the environment, users and samples.

A biological safety cabinet is designed to have: an inflow for protecting the operator from harmful agents inside the cabinet, an ULPA filtered downflow which creates an ISO Class 3 work surface that avoid contamination of the work, experiment or process, and an ULPA filtered exhaust for containing contaminants to protect the environment. It is the most basic safety equipment in laboratory biosafety protection.

Unicorn biological safety cabinets exceed current conventional BSC standards and offer outstanding safety when things don't go as expected. Unicorn gives you **MORE**:

COMPANY INTRODUCTION

From a heritage of more than 15 years experience, Unicorn Medical has contribute to the development of life science, clinical, pharmaceutical, electronics industry, and food industry by innovative solutions for air containment, contamination control and controlled environments. We realize how important to offer a high level of protection to operator, sample and environment with our unique and advanced technologies. With an extensive track record of reliability, safety and performance, We provide higher quality products to meet different applications.

Unicorn air containment and protection product line includes biological safety cabinets, laminar flow cabinets (clean benches), clean booth, dispensing booth, air purifier, air shower, pass box, fan filter units, clear partitions, pressure dampers, etc.

Multiple Technology

Quite, energy-saving motor works with intelligent control system, keeping precise airflow even during ULPA filters loading or temporary obstruction. The BSC automatically balances the downflow and inflow velocities to maintain operator and sample protection. Uniform, non-turbulent air stream protects against cross-contamination.

Outstanding Comfort

With thoughtfully design and features, We provide enhanced comfort including the large colored touch screen for easy monitoring work status, 10° angled sash with more convenient viewing, the large unobstructed working area for equipment placement, and adjustable telescope type stands available.

Reliable Safety

We have been at the forefront of BSC R&D and manufacturing for decades. Each cabinet is designed and produced with a variety of core components and features to improve cleanliness and eliminate sample contamination risk. Visual and acoustic alarm for indication of unsafe airflow condition and window position.

Energy Efficiency

Unicorn BSCs blower save on energy while providing longevity and comfort. It drastically reduces energy consumption, generates less heat for cooler working conditions. The fluorescence light and UV with appointment function consume less. Each cabinet is constructed with more than 70% recycled materials.



COMPLIANCE WITH GLOBAL STANDARD

At Unicorn, we know how important to design a product in compliance with current worldwide safety standards. Unicorn's biological safety cabinet is certified as per CE, EN12469.

EN12469:2000 Biotechnology Performance criteria for microbiological safety cabinets is the new harmonized European standard for microbiological safety cabinets, published by CEN, the European Committee for Standardization. This standard classifies BSCs into Class I, Class II, and Class III.



Worldwide Standard Compliance	
Biosafety cabinets	EN 12469, Europe; CFDA YY0569, China
Air Quality	ISO 14644.1, Class 3, Worldwide US Fed Std 209E, Class 100, USA
Filtration	ISO 29463, Worldwide EN 1822, Europe EN 13091, Europe IEST-PR-CC001.3, Worldwide IEST-PR-CC007.1, Worldwide IEST-PR-CC034.1, Worldwide
Electrical Safety	EN 61010-1, Europe IEC 61010-1, Worldwide EN 61326-1, Europe IEC 61326-1, Worldwide
Quality Management	ISO9001:2008, ISO13485:2003

PRODUCT CLASSIFICATION

Unicorn has developed a wide range of biological safety cabinets to meet diverse application, setting and budget.

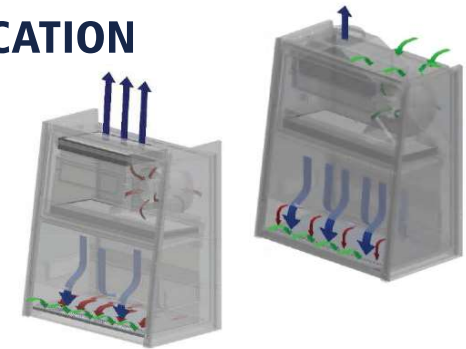

Item	Class II Type A2	Class II Type B2
Protection	Product, Personnel, Environment	Product, Personnel, Environment
Biosafety Level*	1,2,3 and 4	1,2,3 and 4
Ducting	Recirculate to room or vented with Canopy connection & ductwork	100% Vented (Total Exhaust) **
Energy	\$	\$\$\$
Design work	-	+
Flexibility	++	+
Typical Application	Cell/Tissue culture Microbiology Pathology/Clinical Pharmacy Work involving minute volumes of chemicals***	All A2 applications Plus: Work with larger volumes of volatile chemicals
Biotechnology	Medium Preparation Tissue Culture Blood Elements Analysis Human Histology Polymerase Chain Reaction	Medium Preparation Tissue Culture Blood Elements Analysis Human Histology Polymerase Chain Reaction
Microbiology	Medium Preparation Isolated clinical sample Blood test/analysis QA/QC Minute Quantities of Volatile Toxic Chemicals Trace Amount of Radionucleotides	Medium Preparation Culture nuisance odors Isolated clinical sample Blood test/analysis QA/QC Minute Quantities of Volatile Toxic Chemicals Trace Amount of Radionucleotides
Pharmaceutical	General applications	Antitumor drug preparation Trace Amount of Radionucleotides
Routine research	Toxic Powder/ Suspended Substance	Cell/Tissue Immobilization & Staining Toxic Powder/ Suspended Substance

*Biosafety in Microbiological and Biomedical Laboratories (BMBL) 6th Edition.

**Dedicated ductwork required for each Type B2 cabinet per CETA CAG-007

***Canopy connection and exhaust ductwork required.

Blower

- Stable airflow speed despite voltage fluctuations and filter loading by automatic air volume compensation.
- Communicates with airflow sensor through microprocessor, there is no need for additional manual speed control
- Compact and energy-efficient motor runs cooler than other comparable motors, and consumes less energy.
- Quite operation for any comfortable lab conditions. Longer average motor life eliminates service cost.



Velocity Meter



- Imported velocity meter set a new standard in precise downflow airflow speed monitoring to ensure a safe operation.
- Velocity sensor provides instant feedback to the central control system. Auto-adjust BSC airflow as filters load to keep you safe.
- Continuously monitors and maintains inflow and downflow at real-time, and indicated on the large LCD display.
- Alarm thresholds ($\pm 10\%$ of the original set point) are strictly controlled. Alerts will be activated if airflow is insufficient.

Pressure sensor

- Indicate real-time negative pressure between two sides of the downflow filter.

ULPA Filtration System

- 10 x filtration efficiency compared to HEPA filter, creating ISO Class 3 cleanliness instead of industry-standard ISO Class 5
- Utilize ULPA filter (per IEST-RP-CC001.3)/H14 per EN1822 instead of H13 HEPA filters used on many BSCs in the market
- 99.999% at 0.1 to 0.3 micron, ULPA as per IEST-RP-CC001.3 USA or >99.999% at MPPS, H14 as per EN 1822 EU
- Leak-free performance test is carried out regarding structural stability and filter integrity prior to product delivery



Touch Screen Control Panel

- Easy reach & viewing all safety information and performance data on a large touchable screen from a seated position.
- Intuitive interface with easy-to-understand graphics displays airflow velocities, blower condition, filter life, sash status, alarm messages.
- Engage the security lock feature to prevent access to the cabinet by unauthorized or unfamiliar users
- Diagnostics button to easily check the cabinet operating parameters and assist servicing.



Illumination & UV sterilizing

- High quality and brightly fluorescence lamp provides sufficient and uniform illumination for maximum visibility.
- Interlocking function is integrated in the cabinet's control system for UV lamp, fluorescent lamp, front sash window.
- Powerful UV irradiation ensures thorough disinfection. UV lamp appointment saves sterilization waiting time.

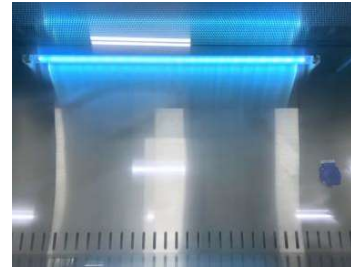

Tempered glass door

- Front sash designed with unobstructed by exterior mounted sash handles ensures convenient use and precise sash opening height position.
- 10° backward-slanted safety grade glass provides a close and comfortable view, with a protection from explosion and UV.
- Counterbalanced sliding sash supported by unique manual lifting system can be raised to a maximum height for easy introduction of large items.



Robust Construction

- All biological safety cabinet structures are subjected to pressure decay method to prevent leakage.
- Seamless, non-porous, autoclavable SUS304 for working table, one-piece side/rear walls and bottom sink.
- Large radius corners is easily cleanable. No welded joints in the work area, reducing the growth of bacteria.
- Removable and divided table top is also available, which is easy to lift, thorough clean and further sterilization.



Arm Rest

- Provides comfortable rear to rest arms, no additional arm rests are needed, preventing grille blocking to guarantee non-blocked airflow.



Receptacles & Service Fixtures

- Waterproof and overload protection. Electrical outlet cover can be opened with one finger and then gently and slowly self-closes.
- Easy to reach service fixture, access for various valves for choice, including Gas, Vacuum, Air, Nitrogen, Water, Universal and etc.
- Optional Vacu-Pass Cord & Cable portal kit for passage of a cable through right-side wall. accommodates cords/cables with different diameters.

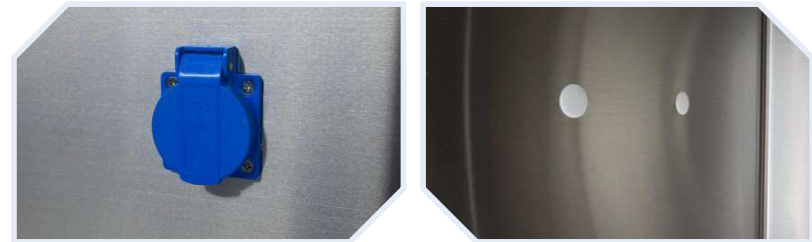

Support Stand

- Support stand is provided to ensure the cabinet stability and ergonomic working position.
- Detachable frame stand is convenient for installation, saving valuable lab space and shipping space as well.
- Manual adjustable leveling feet to compensate for uneven floor. Available with castors for easy re-location or transportation.



INFORMATION CENTER



Touchable LCD Display

Clearly visualizes cabinet conditions in multiple languages (customization is available)

Blower and lights condition

Displays when blower, fluorescence light, UV light are turned On, or Off.

Running Time & Filter Life

Accurately displays remaining ULPA filter life. Alerts users before alarm

Alerts & Alarms

Visual and audible signals notify users of unsafe cabinet conditions

Airflow velocity Data

Keep an eye on downflow and inflow velocities, constant read-out for your safety

Sash Opening Status

Accurate sash opening condition is vital for stable inflow air and biosafety protection

Interface Convenience

Unique BSCs OS incorporate a built-in UV timer and light turn on/off appointment.

Data Connectivity

Exports system information via USB or dry contact relays for remote monitoring.

ALARMS

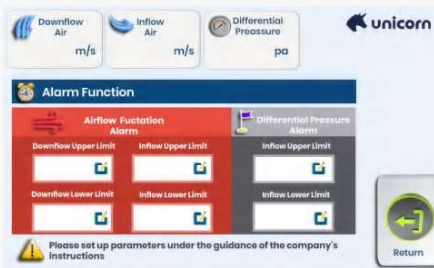

Fan/blower failure alarm

Inflow velocity alarm (upper limit/lower limit setting)

Exhausted airflow alarm (upper limit/lower limit setting)

The slide shutter height alarm/Sash Height limit

Filter high-resistance alarm/Filter Blocked

Filter Lifetime Remind

AIRFLOW PATTERN

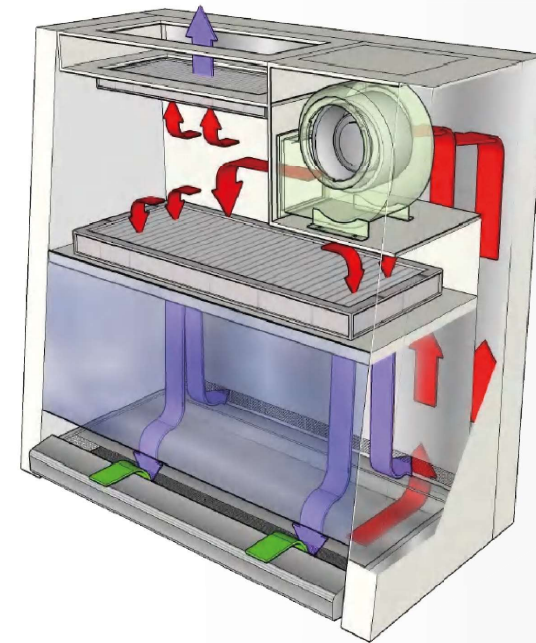

Class II Type A2

Ambient air is pulled through front grille to create inflow, without going into the work surface. Inflow is joined by half of the downflow to create front air curtain that is fine-tuned to create a large performance envelope. The combined air stream travels through the back air column towards the blower.

Approximately 1/3 of the air in the common plenum is exhausted through the ULPA filter to the room. The remaining 2/3 of the air is passed through the downflow ULPA filter and into the work area as a vertical laminar flow air to create ISO Class 3 work surface and prevents cross contamination

Near the work surface, the downflow splits. About half goes to the front grille. And half goes to the rear grille. A small portion enters the side capture zones to prevent dead corners

The design was optimized to give large performance envelope, that provides operator and product protection at wide inflow and downflow variation from the nominal point.



COMPREHENSIVE PERFORMANCE TESTING

Each Biosafety Cabinet produced by Unicorn is individually tested, documented by traceable serial number and validated with the following ways:

Inflow/downflow Velocity Testing

Air velocity is one of the most important parameters to ensure BSC's performance and safety. Velocity test is carried out strictly for each unit before delivery.



PAO aerosol challenge for filter integrity

Scan passing rate of any point in the downflow filter (main filter) by using ATI brand aerosol generator.



Airflow pattern visualization

This test determines that the airflow along the entire perimeter of the work access opening is inward, that airflow within the work area is downward with no dead spots or refluxing.

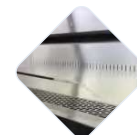

UV radiation test

Safety cabinets installed ultraviolet light, radiation surface in the work area at the wavelength of 254nm ultraviolet, radiation strength is not less than 400mW/m2.



Illumination test

This test determines the light intensity on the work surface of cabinet in foot-candles (lux). A portable photoelectric illumination meter approved for field measurement.

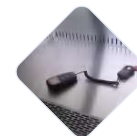

Vibration test

This test determines the amount of vibration in the operating cabinet. A vibration analyzer with a minimum reliable reading of 2.5um rms amplitude.



Air particle count test

This test is carried out to detect the cleanliness of the biological safety cabinet's working area. Laser dust particle counter is utilized.



Microbiological test (bacillus subtilis) *

These tests determine whether aerosols will be contained within the cabinet, outside contaminants will not enter the cabinet work area, and aerosol contamination of other equipment in the cabinet will be minimized.

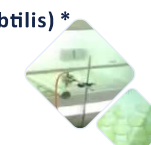

KI-Discus containment test *

Perform the KI Discus test for validating the operator/personnel protection capabilities of biosafety cabinet. The KI-Discus takes only 45 minutes as opposed to 2 days for microbiological testing. Additional KI-Discus containment and microbiological testing are performed on statistical sampling basis.

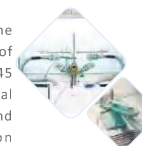

Electrical safety to IEC61010-1&IEC61326

2014/30/EU Electromagnetic Compatibility Directive and 2014/35/EU Low Voltage Directive has been taken as references for these processes.



SERVICE ACCESS AND VALIDATION

Thanks to front open design, all services, adjustments and filter change can easily accessible from the front of the cabinet, allowing for rapid service and minimal work disruption.

Service

All service is performed with accessibility and cleanability to prevent unnecessary contamination. Help for certifiers, the hinged maintenance assembly opens to a fixed position on integrated, gas struts. Consequently, the cabinet can remain in situ without making any positional changes in your laboratory or having to disconnect any ducting. All service is performed from the front of the cabinet, including:

- Fluorescent lamps
- UV lamps
- Change of HEPA filter
- Adjustable or change of circuit boards and sensors
- Adjustment to alarms, fan speed, and control panel

Validation

Unicorn offers professional services for all our equipment, including:

Pre-delivery Services:

- Factory acceptance testing
- Factory service training
- Customized product design

On-site Services:

- Installation qualification
- Operational qualification
- Calibration
- IQ/OQ Protocols are available

On-site consultation:

- Unit specific authorized protocol documents
- Customized testing procedures to meet specific requirements

ENGINEERING DRAWING

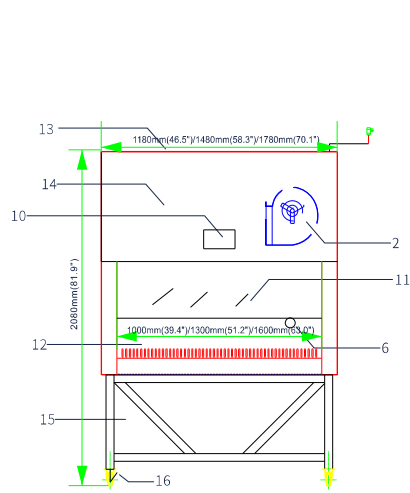

1. ULPA filter,air exhaust
2. Blower
3. ULPA filter,air supply
4. Standard UV light
5. Fluorescent light
6. Universal electrical outlet
7. Downflow sensor
8. Gas/vacuum/water service fixture

9. Stainless steel single-piece work tray
10. Touch screen LCD display
11. Manual sliding sash
12. Single piece stainless steel back wall and side wall
13. Thimble exhaust collar (Optional)
14. Front cover
15. Detachable stand
16. Universal casters

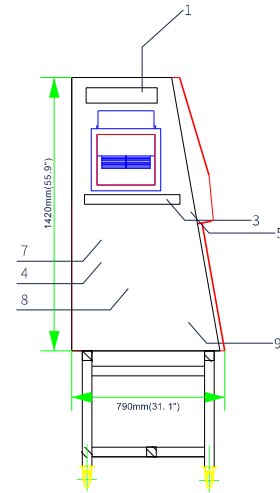

Optional Exhaust Collar Positions for Thimble-Ducting

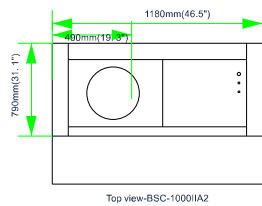

Top view-BSC-1000IIA2

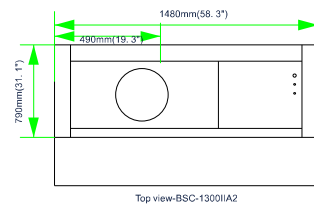

Top view-BSC-1300IIA2

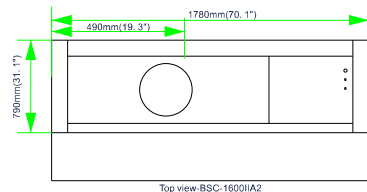

Top view-BSC-1600IIA2

TECHNICAL SPECIFICATIONS

Type	Model	BSC-1000IIA2	BSC-1300IIA2	BSC-1600IIA2
Dimensions	Type of BSC		Class II Type A2	
	Nominal Size	3 feet	4 feet	5 feet
	Usable Working Area	0.672 m ² 7.23 sq.ft.	0.8736 m ² 9.40 sq.ft.	1.0752 m ² 11.57 sq.ft.
	Stand Height (mm)	640mm (25.2") (Adjustable)	640mm (Adjustable)	640mm (25.2") (Adjustable)
	"Internal Work Area, Dimensions(WxDxH)"	1000x672x630mm (39.4"x26.5"x24.8")	1300x672x630mm(51.2"x26.5"x24.8")	1600x672x630mm(63.0"x26.5"x24.8")
	"External Dimensions with Base Stand(WxDxH)"	1180x790x2080mm (46.5"x31.1"x81.9")	1480x790x2080mm(58.3"x31.1"x81.9")	1780x790x2080mm(70.1"x31.1"x81.9")
Airflow	Airflow Mode	70% cycle, 30% exhaust		
	Average Inflow Velocity	0.50m/s (98.4 fpm)		
	Average Downflow Velocity	0.33m/s (65.0 fpm)		
	Inflow Airflow Volume	343m ³ /h (202cfm)	446m ³ /h (263cfm)	549m ³ /h (323 cfm)
	Downflow Airflow Volume	798m ³ /h (470cfm)	1038m ³ /h (611 cfm)	1277m ³ /h (752 cfm)
	Exhaust Airflow Volume	343m ³ /h (202cfm)	446m ³ /h (263cfm)	549m ³ /h (323 cfm)
	Velocity Meter Accuracy	0.001m/s	0.001m/s	0.001m/s
Construction	Blower	AC	AC	AC
	Downflow filter	ULPA	ULPA	ULPA
	Exhaust filter	ULPA	ULPA	ULPA
	Main Body	1.2mm (0.047") 18 gauge Electro-galvanized steel w/with white oven-baked powder-coated finish		
	Work Zone	1.5mm (0.059") 16 gauge Stainless steel, type304, Single-piece or 3-piece		
	Side Walls	1.5mm (0.059") 16 gauge Stainless steel, type304		
	Sash Glass Thickness	5mm(0.197")	5mm(0.197")	5mm(0.197")
	Sash Glass Type	Tempered Glass, UV-proof		
	Sash Window Working Opening	180mm(7.1")	180mm(7.1")	180mm(7.1")
	Sash Maximum Opening	530mm(20.9")	530mm(20.9")	530mm(20.9")
	Fluorescent Light Intensity	≥ 700lux (≥65 foot-candles)		
	RMS	≤ 3um		
	Sound Emission (dBA)	≅ 65dBA		
Cleanliness	Cleanliness	ULPA: Class 3 (ISO 14644.1); Class 100 (Fed 209E)		
	Filter Typical Efficiency	> 99.999% at 0.1 to 0.3 micron, ULPA as per IEST-RP-CC001.3 USA		
		> 99.999% at MPPS, H14 as per EN 1822 EU		
	Personnel Protection Test	KI-Discus containment and microbiological testing are performed		
Controller	Display	7 inches touch screen	7 inches touch screen	7 inches touch screen
	UV Timer	Yes	Yes	Yes
	Main Power Switch	Yes	Yes	Yes
Electrical Data	Cabinet Full Load Amps (FLA)	2.2A	2.2A	2.2A
	Optional Outlet (FLA)	6A	6A	6A
	Nominal Power Consumption (W)	1500W	1500W	1500W
	Power Supply	AC220±10%,50/60HZ	AC220±10%,50/60HZ	AC220±10%,50/60HZ
Alarm	Alarm Type	Audible + Visual		
	Airflow Velocity	Yes	Yes	Yes
	Sash Height Limit	Yes	Yes	Yes
	Filter Remind	Yes	Yes	Yes
Accessories	Fluorescent lamp	30W*2		
	Ultraviolet lamp	30W*1		
	Receptacle (Pieces/Power/Current)	1	1	1
	Detachable Base Stand	Yes	Yes	Yes
	Wheels	Yes	Yes	Yes
	Valve	Optional	Optional	Optional
Weight	Net Weight (kg)	250 Kg (551 lbs)	270Kg (595 lbs)	300 Kg (661 lbs)
	Gross Weight (kg)	275 Kg (606 lbs)	300Kg (661 lbs)	340 Kg (750 lbs)
Shipping	Packing size (WxDxH)	1310x950x2220mm(51.6"x37.4"x87.4")	1610x950x2220mm(63.4"x37.4"x87.4")	1910x950x2220mm(75.2"x37.4"x87.4")
	Shipping Volume	2.76m ³ (97.47 ft3)	3.40 m ³ (120.07 ft3)	4.03 m ³ (142.32 ft3)

ENGINEERING DRAWING

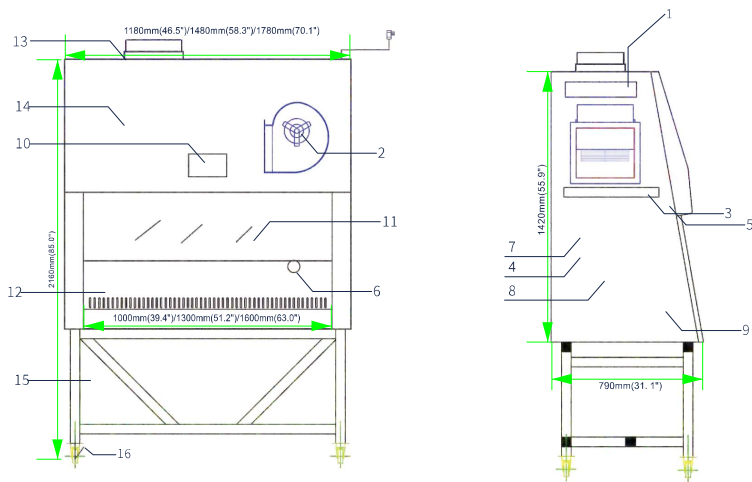

- 1. ULPA filter, air exhaust
- 2. Blower
- 3. ULPA filter, air supply
- 4. Standard UV light
- 5. Fluorescent light
- 6. Universal electrical outlet
- 7. Downflow sensor
- 8. Gas/vacuum/water service fixture
- 9. Stainless steel single-piece work tray
- 10. Touch screen LCD display
- 11. Manual sliding sash
- 12. Single piece stainless steel back wall and side wall
- 13. Thimble exhaust collar
- 14. Front cover
- 15. Detachable stand
- 16. Universal casters

Standard Exhaust Collar Positions for Thimble-Ducting

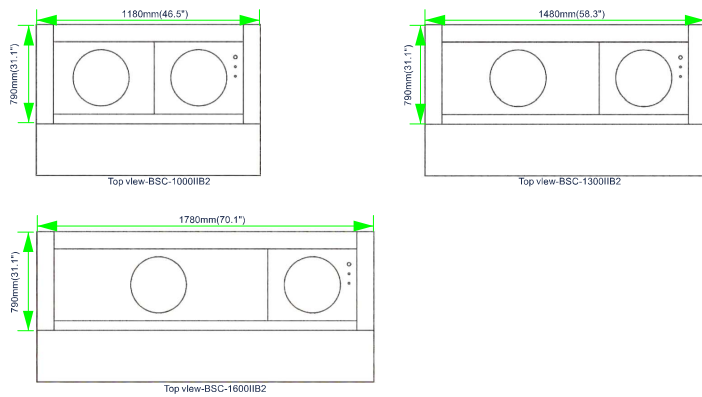

TECHNICAL SPECIFICATIONS

Type	Model	BSC-1000IB2	BSC-1300IB2	BSC-1600IB2
Dimensions	Type of BSC	Class II Type B2		
	Nominal Size	3 feet	4 feet	5 feet
	Usable Working Area	0.672 m ² 7.23 sq.ft.	0.8736 m ² 9.40 sq.ft.	1.0752 m ² 11.57 sq.ft.
	Stand Height (mm)	640mm (25.2") (Adjustable)	640mm (Adjustable)	640mm (25.2") (Adjustable)
	Internal Work Area, Dimensions (WxDxH)	1000x672x630mm (39.4"x26.5"x24.8")	1300x672x630mm (51.2"x26.5"x24.8")	1600x672x630mm (63.0"x26.5"x24.8")
	External Dimensions with Base Stand (WxDxH)	1180x790x2160mm (46.5"x31.1"x81.9")	1480x790x2160mm (58.3"x31.1"x81.9")	1780x790x2160mm (70.1"x31.1"x81.9")
Airflow	Airflow Mode	100% exhaust		
	Average Inflow Velocity	0.53m/s (104.3fpm)		
	Average Downflow Velocity	0.35m/s (68.9fpm)		
	Inflow Airflow Volume	1141m ³ /h (672 cfm)	1484m ³ /h (873 cfm)	1826m ³ /h (1075 cfm)
	Downflow Airflow Volume	798m ³ /h (470 cfm)	1038m ³ /h (611 cfm)	1277m ³ /h (752 cfm)
	Exhaust Airflow Volume	1141m ³ /h (672 cfm)	1484m ³ /h (873 cfm)	1826m ³ /h (1075 cfm)
	Velocity Meter Accuracy	0.001m/s	0.001m/s	0.001m/s
Construction	Blower	AC	AC	AC
	Downflow filter	ULPA	ULPA	ULPA
	Exhaust filter	ULPA	ULPA	ULPA
	Main Body	1.2mm (0.047") 18 gauge Electro-galvanized steel with white oven-baked powder-coated finish		
	Work Zone	1.5mm (0.059") 16 gauge Stainless steel, type304, Single-piece or 3-piece		
	Side Walls	1.5mm (0.059") 16 gauge Stainless steel, type304		
	Sash Glass Thickness	5mm (0.197")	5mm (0.197")	5mm (0.197")
	Sash Glass Type	Tempered Glass, UV-proof		
	Sash Window Working Opening	180mm (7.1")	180mm (7.1")	180mm (7.1")
	Sash Maximum Opening	530mm (20.9")	530mm (20.9")	530mm (20.9")
	Fluorescent Light Intensity	≥ 700lux (≥ 65 foot-candles)		
	RMS	≤ 3um		
	Sound Emission (dBA)	≤ 65dBA		
Cleanliness	Cleanliness	ULPA: Class 3 (ISO 14644.1); Class 100 (Fed 209E)		
	Filter Typical Efficiency	> 99.999% at 0.1 to 0.3 micron, ULPA as per IEST-FP-CC001.3 USA > 99.999% at MPPS, H14 as per EN 1822 EU		
	Personnel Protection Test	KI-Discus containment and microbiological testing are performed		
Controller	Display	7 inches touch screen	7 inches touch screen	7 inches touch screen
	UV Timer	Yes	Yes	Yes
	Main Power Switch	Yes	Yes	Yes
Electrical Data	Cabinet Full Load Amps (FLA)	2.2A	2.2A	2.2A
	Optional Outlet (FLA)	6A	6A	6A
	Nominal Power Consumption (W)	1500W (Excluding external exhaust fan)	1500W (Excluding external exhaust fan)	1500W (Excluding external exhaust fan)
	Power Supply	AC220±10%/50/60HZ	AC220±10%/50/60HZ	AC220±10%/50/60HZ
Alarm	Alarm Type	Audible + Visual		
	Airflow Velocity	Yes	Yes	Yes
	Sash Height Limit	Yes	Yes	Yes
	Filter Remind	Yes	Yes	Yes
Accessories	Fluorescent lamp	30W*2		
	Ultraviolet lamp	30W*1		
	Receptacle (Pieces/Power/Current)	1	1	1
	Detachable Base Stand	Yes	Yes	Yes
	Wheels	Yes	Yes	Yes
	Valve	Optional	Optional	Optional
Weight	Net Weight (kg)	280 Kg (617 lbs)	300Kg (661 lbs)	330 Kg (661 lbs)
	Gross Weight (kg)	305 Kg (672 lbs)	330Kg (661 lbs)	370 Kg (750 lbs)
Shipping	Packing size (WxDxH)	1310x950x2220mm (51.6"x37.4"x87.4")	1610x950x2220mm (63.4"x37.4"x87.4")	1910x950x2220mm (75.2"x37.4"x87.4")
	Shipping Volume	3.06m ³ (108.06 f3)(Including external exhaust fan)	3.70m ³ (130.66 f3)(Including external exhaust fan)	4.33 m ³ (152.91 f3)(Including external exhaust fan)

VERTICAL CLEAN BENCH

Introduction

Vertical laminar flow cabinet (clean bench) is a carefully enclosed bench designed to maintain a sterile work space whereas contaminant access is being prevented for biological samples, semiconductor wafers or any particle sensitive materials. Air goes through a HEPA filter and generate a filtered airflow across the surface. The cabinet internal working area is made of stainless steel with no gaps or joints where spores might collect.

A vertical laminar flow cabinet is recommended if there is a need to put large objects/equipment inside the working area, since there is no blocking of the airflow. It is ideal for use in microbiology (non-pathogenic), forensic, sterile product compounding and other non-hazardous applications that need sterile environment.



Features

- The laminar flow cabinet/clean bench adopts cold-rolled steel plate spraying process, and the appearance is finely sprayed.
- It adopts high-efficiency filter with aluminum frame and no partition, and the filtration efficiency is 99.995% ($\geq 0.3\mu\text{m}$ particles).
- The centrifugal blower is used to keep the downflow airflow velocity stable and continuous, effectively prolonging the service life of the high efficiency filter.
- The working table is made of integrated stainless steel, which is corrosion-resistant and easy to clean.
- Back or double-side perspective window design, better lighting effect and wider field of view.
- With reasonable structural design, the maintenance and replacement of high-efficiency filters and blowers can be carried out on the top of the clean bench, which is more convenient and faster.
- The closed table top can effectively prevent the harm of the human body from the entry of external air and the odor of the operating area.

Specifications

Model	UCB-VF1A	UCB-VF2A
Cleanliness in Work Area	ISO Class 5, Class 100 (Fed 209E)	ISO Class 5, Class 100 (Fed 209E)
HEPA filter	Filters provide more than 99.99% typical efficiency for particle size greater than 0.3 microns	
Average air velocity	0.3~0.5m/s (adjustable)	0.3~0.5m/s (adjustable)
CFU	$\leq 0.5/\text{dish} \cdot \text{hour} (\phi 90\text{mm Petri dish})$	$\leq 0.5/\text{dish} \cdot \text{hour} (\phi 90\text{mm Petri dish})$
Sound Emission	$\leq 65 \text{ dB(A)}$	$\leq 65 \text{ dB(A)}$
RMS	$\leq 4\mu\text{m}$	$\leq 4\mu\text{m}$
Fluorescent light	16W LED $\times 1$	16W LED $\times 1$
UV light	21W $\times 1$	21W $\times 1$
Power Supply	AC220 $\pm 10\%$, 50Hz $\pm 2\text{Hz}$	
Maximum power consumption	$\leq 0.5\text{kW}$	$\leq 0.8\text{kW}$
External Dimensions with Base Stand	1000*740*1650mm	1480*740*1700mm
Internal Work Area, Dimensions (WxDxH)	840*680*520mm	1320*680*520mm
Net Weight/Shipping Weight (kg)	50KG	80KG

HORIZONTAL CLEAN BENCH

Introduction

Horizontal laminar flow cabinet (clean bench) is a carefully enclosed bench designed to maintain a sterile work space whereas contaminant access is being prevented for biological samples, semiconductor wafers or any particle sensitive materials. A purified air travels in horizontal, unidirectional stream and leaves the main work chamber across the entire open front of the cabinet. The cabinet internal working area is made of stainless steel with no gaps or joints where spores might collect.

A horizontal laminar flow cabinet is recommended if samples are sensitive since the airflow will not directly blow to the samples. It is ideal for use in plant tissue culture, culture media preparation, electronics inspection, medical device assembly and other non-hazardous applications that need sterile environment.



Features

- The laminar flow cabinet/clean bench adopts cold-rolled steel plate spraying process, and the appearance is finely sprayed.
- It adopts high-efficiency filter with aluminum frame and no partition, and the filtration efficiency is 99.995% ($\geq 0.3\mu\text{m}$ particles).
- The centrifugal blower is used to keep the horizontal airflow velocity stable and continuous, effectively prolonging the service life of the high efficiency filter.
- The working table is made of integrated stainless steel, which is corrosion-resistant and easy to clean.
- Back or double-side perspective window design, better lighting effect and wider field of view.
- With reasonable structural design, the maintenance and replacement of high-efficiency filters and blowers can be carried out on the top of the clean bench, which is more convenient and faster.
- The closed table top can effectively prevent the harm of the human body from the entry of external air and the odor of the operating area.

Specifications

Model	UCB-HF1A	UCB-HF2A
Cleanliness in Work Area	ISO Class 5, Class 100 (Fed 209E)	ISO Class 5, Class 100 (Fed 209E)
HEPA filter	Filters provide more than 99.99% typical efficiency for particle size greater than 0.3 microns	
Average air velocity	0.3~0.5m/s (adjustable)	0.3~0.5m/s (adjustable)
CFU	$\leq 0.5/\text{dish} \cdot \text{hour} (\phi 90\text{mm Petri dish})$	$\leq 0.5/\text{dish} \cdot \text{hour} (\phi 90\text{mm Petri dish})$
Sound Emission	$\leq 65 \text{ dB(A)}$	$\leq 65 \text{ dB(A)}$
RMS	$\leq 4\mu\text{m}$	$\leq 4\mu\text{m}$
Fluorescent light	16W LED $\times 1$	16W LED $\times 1$
UV light	21W $\times 1$	21W $\times 1$
Power Supply	AC220 $\pm 10\%$, 50Hz $\pm 2\text{Hz}$	
Maximum power consumption	$\leq 0.5\text{kW}$	$\leq 0.8\text{kW}$
External Dimensions with Base Stand	1000*750*1470mm	1500*750*1470mm
Internal Work Area, Dimensions (WxDxH)	920*500*600	1420*500*600
Net Weight/Shipping Weight (kg)	50KG	80KG

Shanghai Unicorn Medical Technology Co., Ltd.

Room J, Building 4, B Zone, No. 925 Yecheng Road, Jiading Industrial Area, Shanghai

Tel: +86 (021) 6082 8473 Cel: +86 183 6102 8973 Email: info@unicornlifescience.com

www.unicornlifescience.com

Information is subject to change and/or updating without notice
@ 2023 Unicorn. LIFE-CLEANAIRSOLUTION-202301